

This Tool !

- Center-drilling and chamfer process can be done by this Tool. You can reduce numbers of ATC tooling by using this tool and make high productivity!
- Original insert shape designed by us solved risk of Chattering and breakage

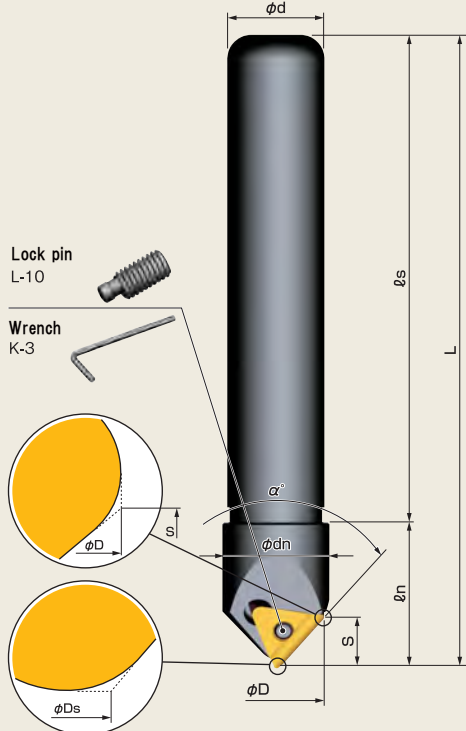

Achieved large Capacity Cutting of Center-Drilling(22.5mm) and C-Face Chamfering(C8mm).

Processing Example

[$\phi 20$ of Centering Processing]

- Body : SC2045T
- Insert : T32GUX NK3030
- Material.....S50C
- Rotation Speed...2,500r.p.m
- Feed (Z-axis).....80mm/min
- Cutting Oil.....Yes



Result

Good! No secondary burrs and no chattering process



※ This tool cannot be used with drilling machines

Dish Chamfering Processing (Min. Blade Diameter~Max. Blade Diameter)

90°
 $\phi 3\text{mm} \sim \phi 22.5\text{mm}$

120°
 $\phi 3\text{mm} \sim \phi 26.6\text{mm}$

Body

Model. No.	Blades	Dimensions (mm)								α°
		ϕD	ϕD_s	ϕd	ϕd_n	L	ℓ_s	ℓ_n	S	
SC2045T	1	22.5	1.99	20	22	130	100	30	10.5	90°
SC2045TL	1	22.5	1.99	20	22	200	170	30	10.5	90°
SC2545TL	1	22.5	1.99	25	22	200	150	50	10.5	90°
SC2530T	1	26.6	1.90	25	25	130	95	35	7.5	120°
SC3230TL	1	26.6	1.90	32	25	200	150	50	7.5	120°

※ Inset is not Included. Please Order Separately.

※ Lock pin Wrench we have Standard Equipment.

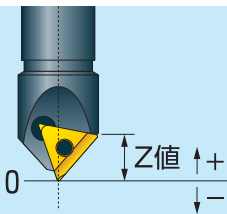

Z-value compensate standard

※ Please note that this value may be getting little errors

$\alpha^\circ = 90^\circ \rightarrow +0.8$

$\alpha^\circ = 120^\circ \rightarrow +0.6$

[Example]

Correct Z-value(-10.0)to -9.2in case of $\phi 20\text{mm}$ spot drilling process

Cutting Conditions

Centering				
Material	Feed Per Blade (fz)	Rotation Speed (r.p.m.)	Recommended Insert	Coolant
General Steel	0.03~0.08	1,500~2,500	T32GUX NK2020	Yes
Alloy Steel	0.03~0.08	1,500~2,500	T32GUX NK3030	Yes
Stainless Steel	0.03~0.08	1,500~2,500	T32GUX NK6060	Yes
Aluminum,Resin,Brass	0.03~0.1	3,000~	T32GUX NK1010	Yes
Castings	0.03~0.08	1,500~2,500	T32GUX NK3030	Yes

Chamfering				
Material	Feed per blade (fz)	Rotation speed (r.p.m.)	Recommended Insert	Coolant
General Steel	0.1~0.2	1,500~	T32GUX NK2001	None
Alloy Steel	0.1~0.2	1,500~	T32GUX NK2001	None
Stainless Steel	0.1~0.2	1,500~	T32GUX NK6060	Yes
Aluminum,Resin,Brass	0.1~0.2	2,000~	T32GUX NK1010	Yes
Castings	0.1~0.2	1,500~	T32GUX NK2001	None

- In case of bore chamfering process by Z-axis only, please take same cutting condition of centering process
- According to the shape of work, large or small chamfering, amount and position of blade, the cutting condition will have to be adjusted.
- In case of process with large amount chamfer, please take reducing cutting condition
- In case of chamfering process of stainless steel, please take the down cutting

Insert

Figure	Model.No.	Material	Blade Shape	Coating	Usable corner	Quantity per box
	T32GUX NK2001	Cermet	Honing edge	None	2	12
	T32GUX NK1010	Carbide K10	Sharp edge	None	2	12
	T32GUX NK2020	Carbide M20	Honing edge	None	2	12
	T32GUX NK3030	Carbide M20	Honing edge	TiN	2	12
	T32GUX NK5050	Carbide K10	Sharp edge	TiN	2	12
	T32GUX NK6060	Carbide M20	Honing edge	TiAlN	2	12
	T32GUX NK8080	Carbide K10	Sharp edge	TiAlN	2	12
	T32GUXF AC16N	Fine particles Carbide	Sharp edge	AlCrN	2	12
	T32GUXT AC16N	Fine particles Carbide	Honing edge	AlCrN	2	12
	T32GUX HSS	HSS	Sharp edge	None	2	12
	T32GUX HSS TiN	HSS	Sharp edge	TiN	2	12



Blade edge by centering processing could not be a perfect vertex angle

When mounting insert, please do not take reverse tightening.

Due to the eccentricity looking mechanism, poor accuracy or breakage of insert may be occurred

When replacing insert, please confirm whether you have been taking reserve tightening or not.

...P.114